

REVISION HISTORY			
REV.	DESCRIPTION	DATE	DRAWN BY
1	ORIGINAL PRINT	9/29/2021	B. HEININGER

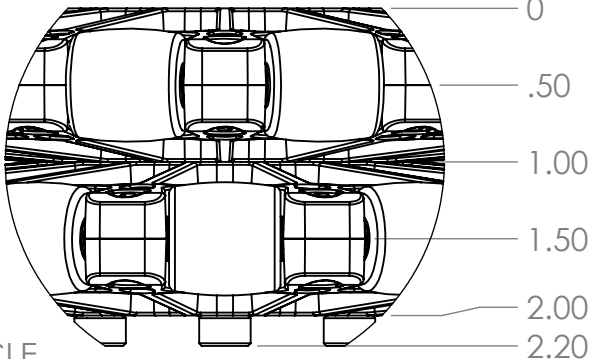

DETAIL C
SCALE 2 : 2.5

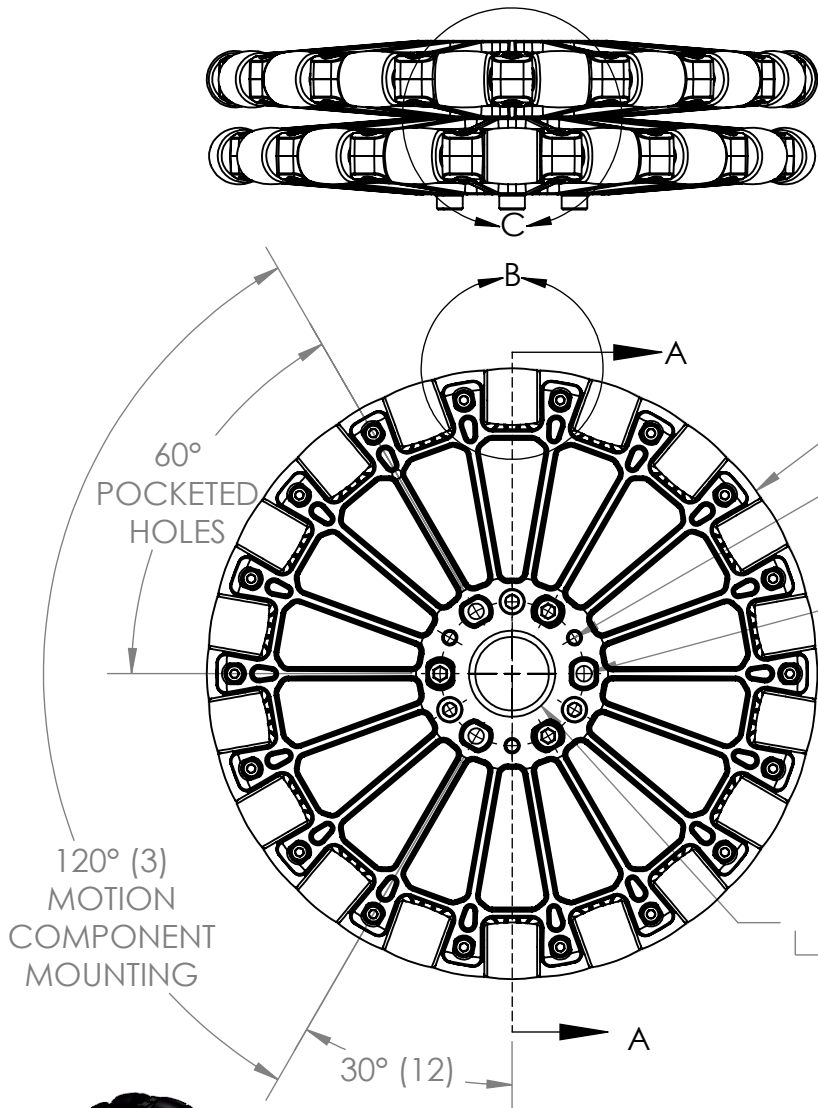
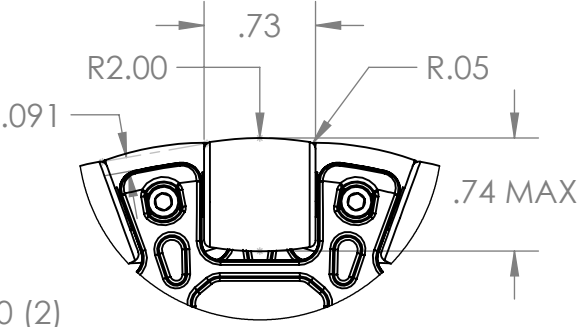

DETAIL B
SCALE 2 : 2.5

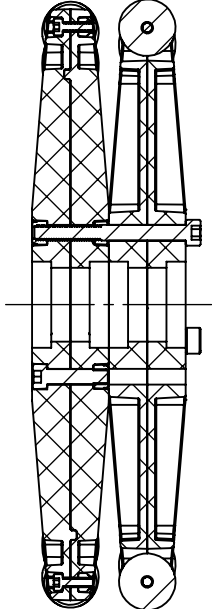

SECTION A-A

*** SEE CAD FOR ADDITIONAL TOOLPATH INFO***

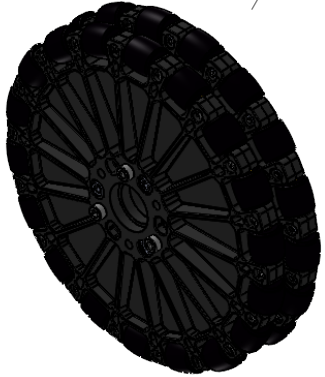

UNLESS OTHERWISE SPECIFIED:		COMMENTS:	
DIMENSIONS ARE IN INCHES		DUAL DIMENSIONS ARE IN MILLIMETERS.	
TOLERANCES:		BREAK ALL SHARP EDGES.	
FRACTIONAL	±1/16		
ANGULAR: MACH	±1°		
ANGULAR: BEND	±5°		
ONE PLACE DECIMAL	±0.1		
TWO PLACE DECIMAL	±0.01		
THREE PLACE DECIMAL	±0.005		
FOUR PLACE DECIMAL	±0.0005		
MATERIAL	POLYCARBONATE BODY SBR RUBBER ROLLERS	NAME	DATE
FINISH	ASSEMBLED	CHECKED	NL 9/30/21
		ENG APPR.	
		MFG APPR.	
		Q.A.	
DO NOT SCALE DRAWING			



TITLE:
**8 IN PLASTIC
DUALIE OMNI WHEEL**

SIZE	DWG. NO.	REV
A	am-0463a	1
SCALE: 1:2.5		SHEET 1 OF 1